

Pergola T4

Aluminum canopy structure, with packaging retractable awning, consisting in a fabric fixed to a crossbars and guides system, that allows the horizontal sliding. The structure rests on two small but very strong side brackets of an attractive design. It is stabilized by flat matching braces for a total thickness of 30mm. Guaranteed wind resistance up to class 3 according to UNI EN 13561. The development of condensation on the fabric is natural and not to be considered as a defect.

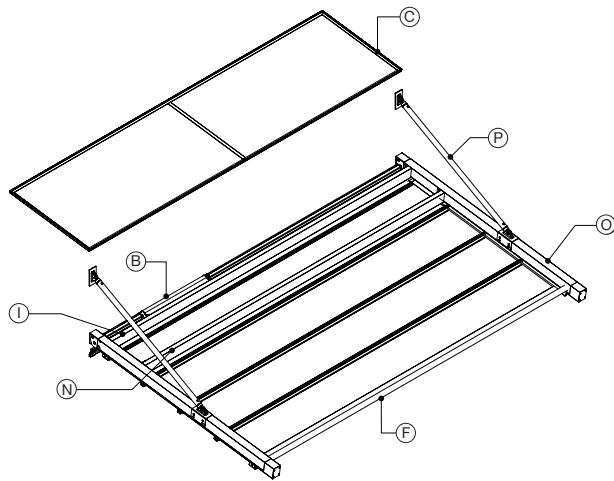

- C Protection hood
- B Moving electrical control
- I Supporting motor crossbar profile
- O Sliding guide
- F Frontal girder
- N Supporting hood crossbar profile
- P Tightener



adrems

Stínící technika a dekorace oken.



Schema tecnico generale/General technical plan/Allgemein -
technisches Schema/Plan technique général/Dibujo tecnico general

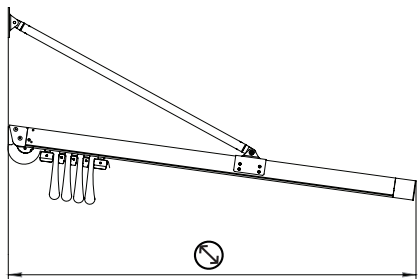

Larghezza interasse guide/Guides interaxis width/Breite des
Achsabstandes der Führungsschienen/Largeur entraxe coulisses/
Linea guía intereje

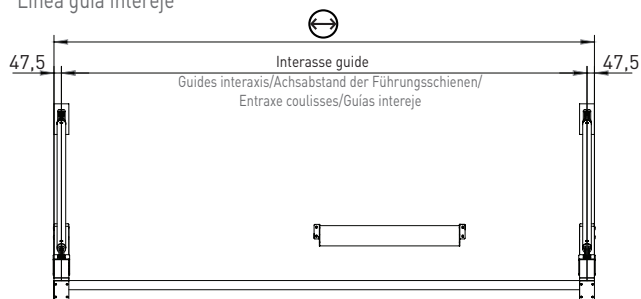

Dimensioni profili/Profiles dimensions/Profilabmessungen/
Mesures profils/Dimensiones perfiles

Guida Guide Führungsschiene Glissière Guía	Terminale Terminal bar profile Fallstange Barre de charge Terminal	Traverso Porta Tessuto Fabric carrying Crossbar profile Stoffquerträger Profil de traverse porte tissu Palillo	Profilo supporto guida Guide support profile Tragprofil für Führungsschiene Profil support coulisse Perfil soporte guía



Applicazione a parete/Wall installation/Wandmontage
Pose au mur/Instalación a pared

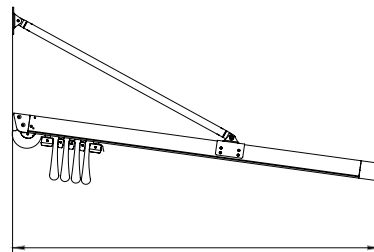

Applicazione lato guida/Application slide side/Anwendung Seiten-
führungsschiene/Application cote glissière/Instalacion lado guía

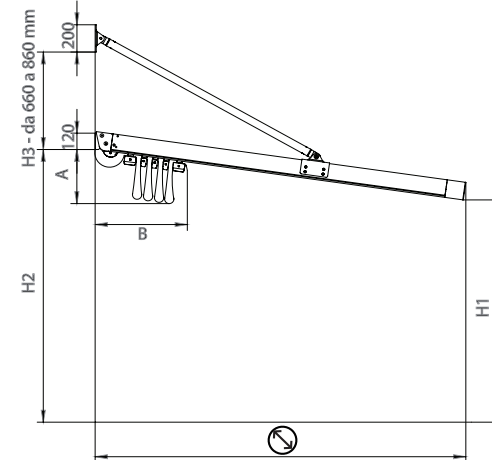
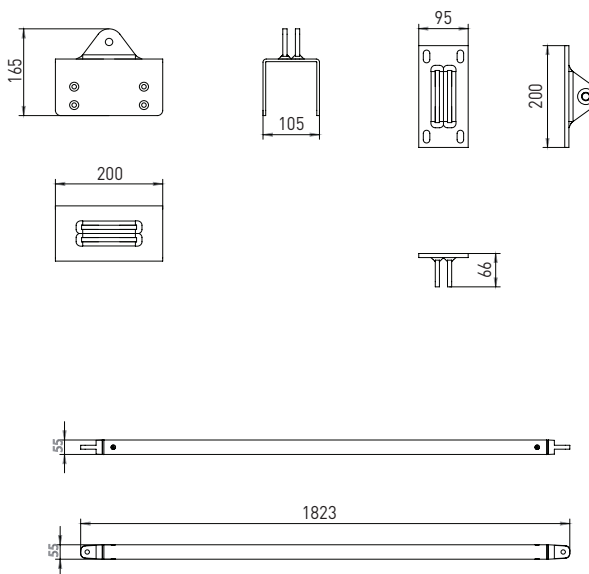

Valori indicativi degli ingombri del telo e del numero di traversi portatelo.
Attenzione: i valori esposti possono variare a seconda della pendenza.

Indicative values of the fabric encumbrance and the number of the fabric carrying crossbar profiles.
Attention: the indicated values may change according to the inclination.

Richtwerte der Ausmaße des Tuches und der Anzahl der Stoffquerträger Achtung: die
angegebenen Werte können sich je nach Gefälle ändern.

Valeurs indicatives des encombrements de la toile et du nombre de profils de traverse
porte tissu. Attention: les valeurs peuvent changer selon la pente

Valores indicativos de las dimensiones del tejido y del numero de palillos.
Atención: los valores indicados pueden cambiar según la inclinación.

	A cm	B cm	N
250	42	63	5
300	42	63	5
350	43	69	6
400	43	74	7

N Numero traversi (compreso terminali). Misura massima interasse traversi
portatelo 62 cm.

N Crossbar profile numbers (terminals included). Maximum interaxis fabric
carrying crossbar profiles measure cm 62.

N Anzahl der Querträger (inklusive Fallstangen). Maximaler Achsabstand
der Stofftragerschienen cm 62.

N Nombre profils de traverse (compris barres de charge).
Mesure maximale entraxe profils traverse porte tissu cm 62.

N Numero de perfiles transversales (terminales incluidos). Medida
màxima intereje perfiles transversales para lona cm 62.

adremS

Stínící technika a dekorace oken.